

TECHNICAL INFORMATION COMMUNICATION



**United
Technologies**

Building & Industrial Systems

Quality and Continuous Improvement

Number: TIC2014-0001

Date: 1/14/2014

Title: New Trap Heater Kit

Product Category: Gas Furnaces

Products Affected

35" Condensing Gas Furnaces

Situation

Effective January 1, 2014, the condensing gas furnace trap heater kit, KGAHT0201CFP, is now available for shipment to all distributors. The condensate freeze protection (condensate trap with heat pad) kit is designed to protect a high-efficiency furnace condensate drain trap from freezing when the furnace is installed in an area where temperatures may be below 32F (0C).

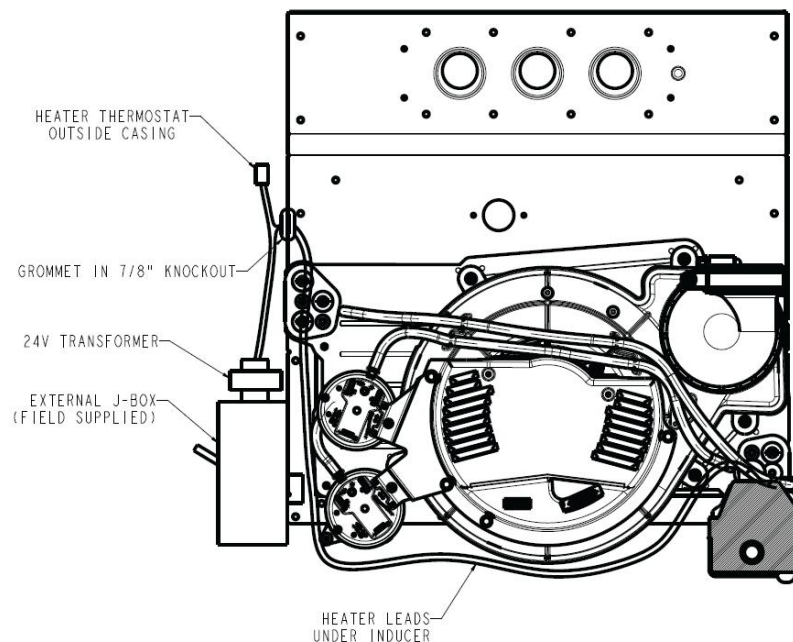

The trap heater kit includes a completely new trap with the heating pad affixed to it to prevent freezing of condensate in the trap. The kit also includes a step-down transformer that provides the 24V required for the heating pad, and an in-line thermostat to turn on the heating pad when ambient temperatures reach 35 degrees.

References

Bulletins: 101-14-01, BY-103-14-01, PY-103-14-01

Only trained and qualified personnel should design, install, repair and service HVAC systems and equipment. All national standards and safety codes must be followed when designing, installing, repairing and servicing HVAC systems and equipment. It is the responsibility of the Dealer to ensure local codes, standards, and ordinances are met.